

# GLASS RAILING MEASURING GUIDE

## THE TOOLS YOU'LL NEED



measuring tape



pencil

## PREPARATION

Although our Frameless Glass Railing System allows considerable room for adjustments, Ordering the correct glass size is critical for a proper installation. The drawings on the following pages are designed to help you provide us with the proper measurements. Please remember that we can never have too much information regarding your application.

## GENERAL MEASURING RULES

- 1 **All measurements are assumed to be centerline, unless noted otherwise.**
- 2 **For installation on wood deck surfaces, spigot screw holes must be aligned with proper deck blocking. Before installing the spigots, make sure to install blocking where required.**
- 3 **How accurate do the measurements have to be to place an order?**  
Each gap can be adjusted during the final installation process. Longer railing span allows for a bigger margin of error and vice versa.
  - Span with 2 panes or less- within 1/2" accuracy
  - Span with 4 panes or less - within 3/4" accuracy
  - Span with 4 panes or more - within 1" accuracy
- 4 **In order to specify the proper span length measurements for a multiple span install, the centerline of each section has to be identified.**
- 5 **For installation on concrete surfaces, spigot screw holes must be at a minimum of 2" from the edges.**

Generally, we suggest allowing a min 2" gap from the concrete slab edge to the closest spigot drilling hole, which will bring the centerline of your spigot (and therefore your glass fence centerline) to about 3-1/2" away from the edge.

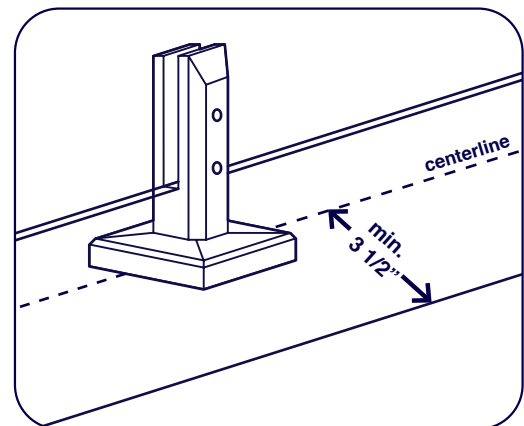

# INLINE MEASURING GUIDE

## 1 Span Length

Determine your railing centerline.

Specify your total span length, If your railing is between 2 walls or a column, please specify the wall to wall dimension.

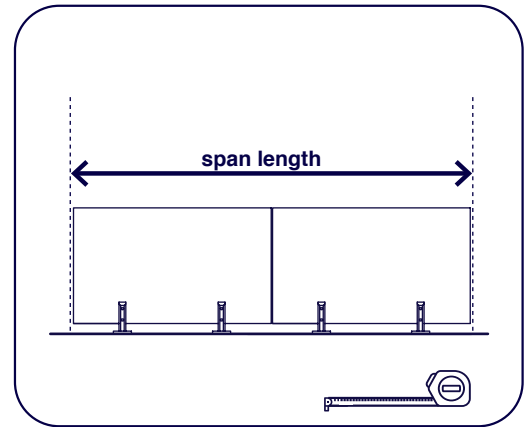

# L-SHAPE MEASURING GUIDE

## 1 Determine the centerline of both axis

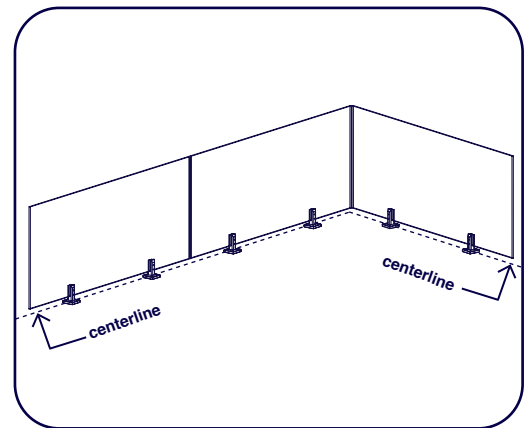

## 2 Determine the intersection point of both centerlines

**Span 1:** Measure from starting point (A) to the point of intersection (B).

**Span 2:** Measure from point of intersection (B) to end point (C).

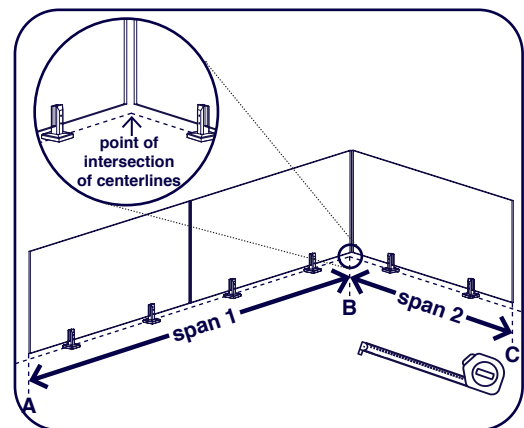

# U-SHAPE MEASURING GUIDE

**1 Determine the centerline of all axis**

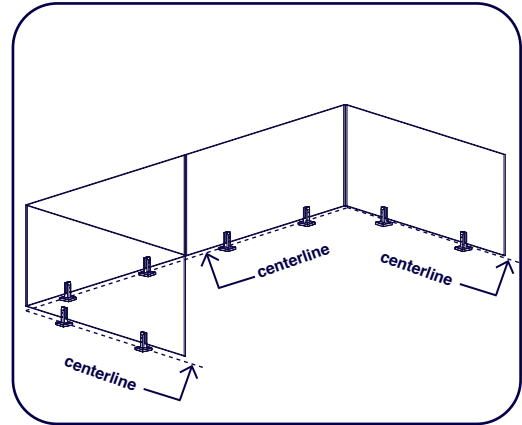

**2 Determine the 2 intersection points of centerlines found in step 1.**

**Span 1:** Measure from starting point (A) to the point of intersection (B)

**Span 2:** Measure from point of intersection (B) to the point of intersection (C).

**Span 3:** Measure from point of intersection (C) to the end point (D).

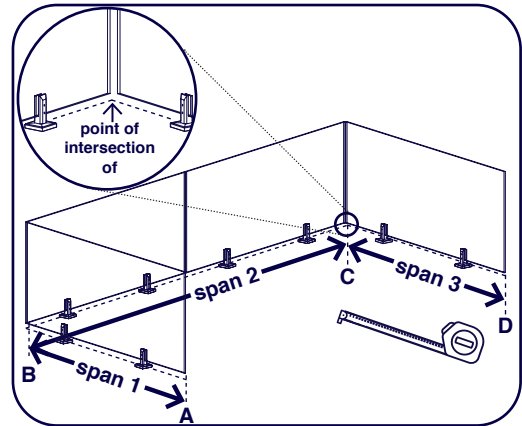

# ENCLOSED MEASURING GUIDE

**1 Determine the centerline of all axis**

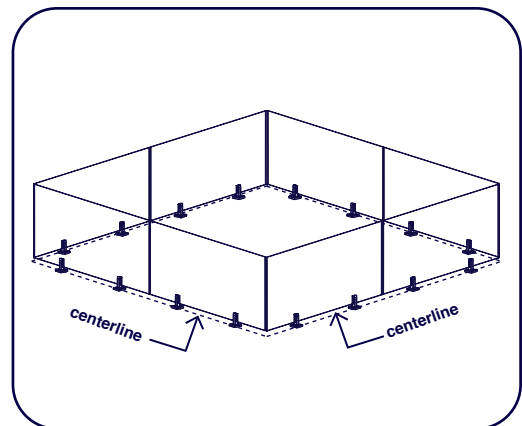

**2 Determine the 2 intersection points of centerlines found in step 1.**

**Span 1:** Measure from starting point (A) to the point of intersection (B)

**Span 2:** Measure from point of intersection (B) to the point of intersection (C).

**Span 3:** Measure from point of intersection (C) to the point of intersection (D).

**Span 4:** Measure from point of intersection (D) to the end starting point (A).

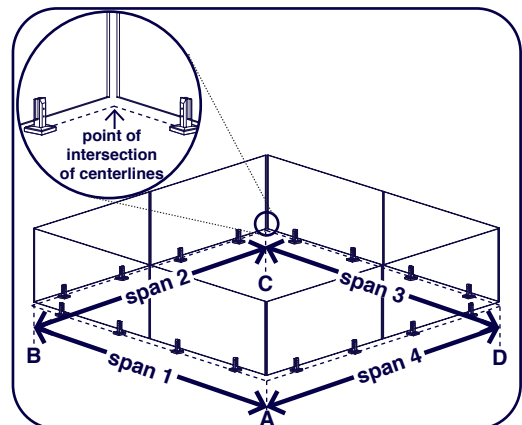

# STAIRS MEASURING GUIDE

Measuring stairs is relatively easy if you carefully follow the few steps below. when measuring for a staircase application, provide measurements within a 1/16 of an inch.

Two different methods are available to provide accurate staircase measurements. Select the technique that suits you best.

Refer to the diagram below:

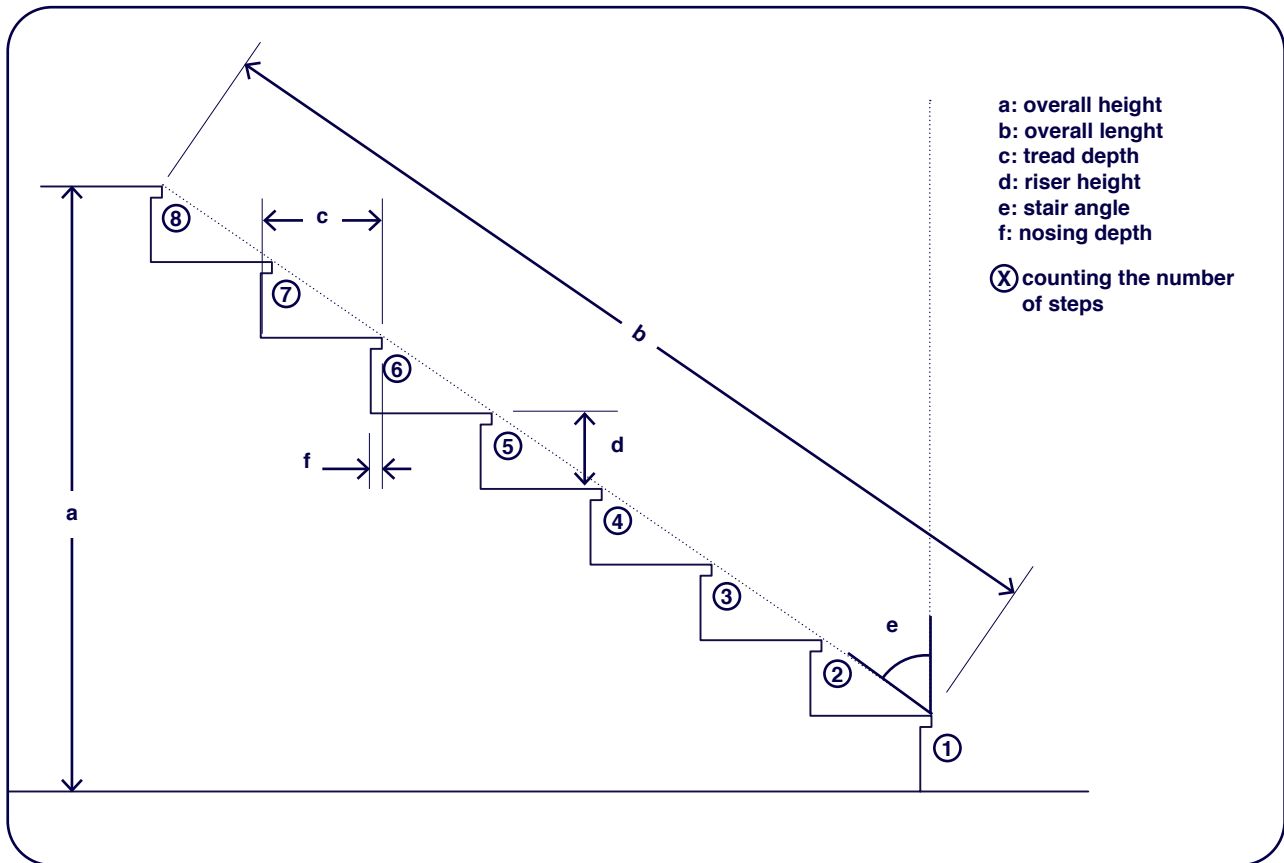

## **METHOD 1 - DIGITAL LEVEL**

A fast and precise method for measuring stairs is to use a digital level. if you have a smartphone you can download a digital level app. See links below.

Android phones:

<https://play.google.com/store/apps/details?id=com.plaincode.clinometer&hl=en>

Apple phones:

<https://itunes.apple.com/us/app/clinometer+-+bubble-level/id286215117?mt=8>

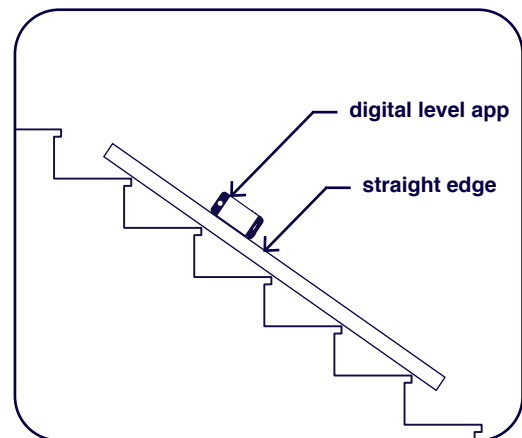

You will still have to supply us with a few measurements such as the tread rise measurements, the overall number of risers and the overall length for this method to work.

- 1 Count the number of steps**  
When counting for the number of steps, count the tread noses to determine the number of steps.
- 2 Find stairs angle**  
Be sure to lay the digital level across a number of treads(steps) using a straight edge (a board or a long level).
- 3 Measure the overall length**  
When determining the overall length, measure the horizontal distance from the edge of the nosing on the first tread at the bottom of the staircase to the edge of the nosing on the floor/landing at the top of the staircase.
- 4 Measure height of finished tread**  
To obtain this measurement, measure the height of a riser from the base tread to the tread of the next stair above it.

## **METHOD 2 - WITHOUT DIGITAL LEVEL**

If the digital level is not an option, follow the five easy steps below to obtain the measurements necessary for your staircase application. For this method to work, You will have to provide us with 2 extra measurements.

- 1 Count the number of steps**  
When counting for the number of steps, count the tread noses to determine the number of steps.
- 2 Measure the overall height**  
The overall height is the distance from the floor or landing at the top of the set of stairs to the floor/landing at the bottom of the set of stairs.
- 3 Measure the overall length**  
When determining the overall length, measure the horizontal distance from the edge of the nosing on the first tread at the bottom of the staircase to the edge of the nosing on the floor/landing at the top of the staircase.
- 4 Measure depth of finished tread**  
To obtain this measurement, measure the length of one finished tread (from front to back).
- 5 Measure height of finished tread**  
To obtain this measurement, measure the height of a riser from the base tread to the tread of the next stair above it.
- 6 Measure length of nosing**  
To obtain the length of the nosing, measure the top edge of the nosing of the first tread to the top edge of the floor/landing nose. Do not confuse this measurement with the overall length.